



YANMAR

V120

WHEEL LOADER



Operating weight

7 000 kg

Engine

Deutz TCD 3.6 L4 EU Stage V

Net Power

74,4 kw (101 HP)

Bucket capacity

1,2 – 1,8 m³

Steering

Articulated

POWER, PERFORMANCE AND RELIABILITY – THE PERFECT COMBINATION





ARTICULATED STEERING

Designed to excel, the V120 features articulated steering and rear axle oscillation. This allows precise machine operation and ensures a short turning radius – hugely beneficial when changing attachments. Operators benefit from impressive stability, class-leading reliability and unparalleled comfort.



UNIQUE OPERATOR CONTROL

Thanks to Yanmar's proprietary Smart Control operating system, operators can match excavator power to specific jobsite requirements. This capability maximises productivity, further improves cycle times and guarantees class-leading performance.



STATE-OF-THE-ART ENGINE

Powered by a four-cylinder turbocharged Stage V-compliant diesel engine, fitted with DPF and charge cooler as standard, the V120 sets the standards in fuel efficiency and environmentally friendly operation. Common rail technology and direct injection functionality maximises performance, providing total control for the operator.



OPTIMAL LOADING

Featuring state-of-the-art parallel kinematics, the V120 can be loaded quickly and precisely without the need to continuously adjust the load angle.



EASY OPERATION

Thanks to multi-functional joysticks, fingertip operation and Smart Control, operators benefit from precise, productive, easy and enjoyable machine control – the perfect partner for productivity.



COMFORTABLE CAB

Designed with the operator firmly in mind, the V120 cabin is spacious and comfortable. Ergonomic control arrangement, class-leading visibility and state-of-the-art display screens create the perfect environment for safe and productive operation.



MANAGEABLE MAINTENANCE

A large engine hood provides easy access to all major service items. Clever design allows daily maintenance to be undertaken from ground level, ensuring maximum safety and contributing to a low Total Cost of Ownership.



FAST ATTACHMENT CHANGES

Thanks to a fast and powerful two-handed quick-hitch system, operators can change attachments directly from the cabin. This not only saves time, but also further improves on-site safety.

UNMATCHED PRODUCTIVITY



The perfect combination of power and performance, the V120 adopts next-generation technologies to maximise productivity and minimise environmental impact. Designed with the operator in mind, it delivers over and above expectations – regardless of terrain or application.



COMPACT DESIGN

With a height of 2,780mm, width of 2,100mm (with bucket), length of 5,480mm and turning radius (track circle) of 2,155mm, the V120 is compact, versatile and highly manoeuvrable.

ARTICULATED STEERING WITH OSCILLATING REAR AXLES

Perfect for use on tight urban job sites where space comes at a premium, the V120 has been designed to deliver unmatched manoeuvrability. Articulated steering allows the bucket to approach the load in a straight line, even at the maximum steering angle (40°) – further improving productivity, especially when picking up pallets or placing loads.

The oscillating rear axle has a slewing angle of 8° and ensures that all four wheels remain in contact with the ground, even while working on uneven terrain. This means that the weight of the machine moves in the same direction of the bucket, which increases pressure on the ground when reversing.

LIFTING FRAME

PARALLEL KINEMATICS

Adopting Yanmar's state-of-the-art parallel kinematics system, operators can lift a load quickly and precisely without having to adjust the load angle. This leaves the operator free to concentrate on the job in hand - improving productivity and maximising on-site safety.

This is particularly helpful when loading and unloading the second row on a truck. The clever design ensures the tilt control lever doesn't collide with the body of the truck, improving efficiencies and maximising productivity.

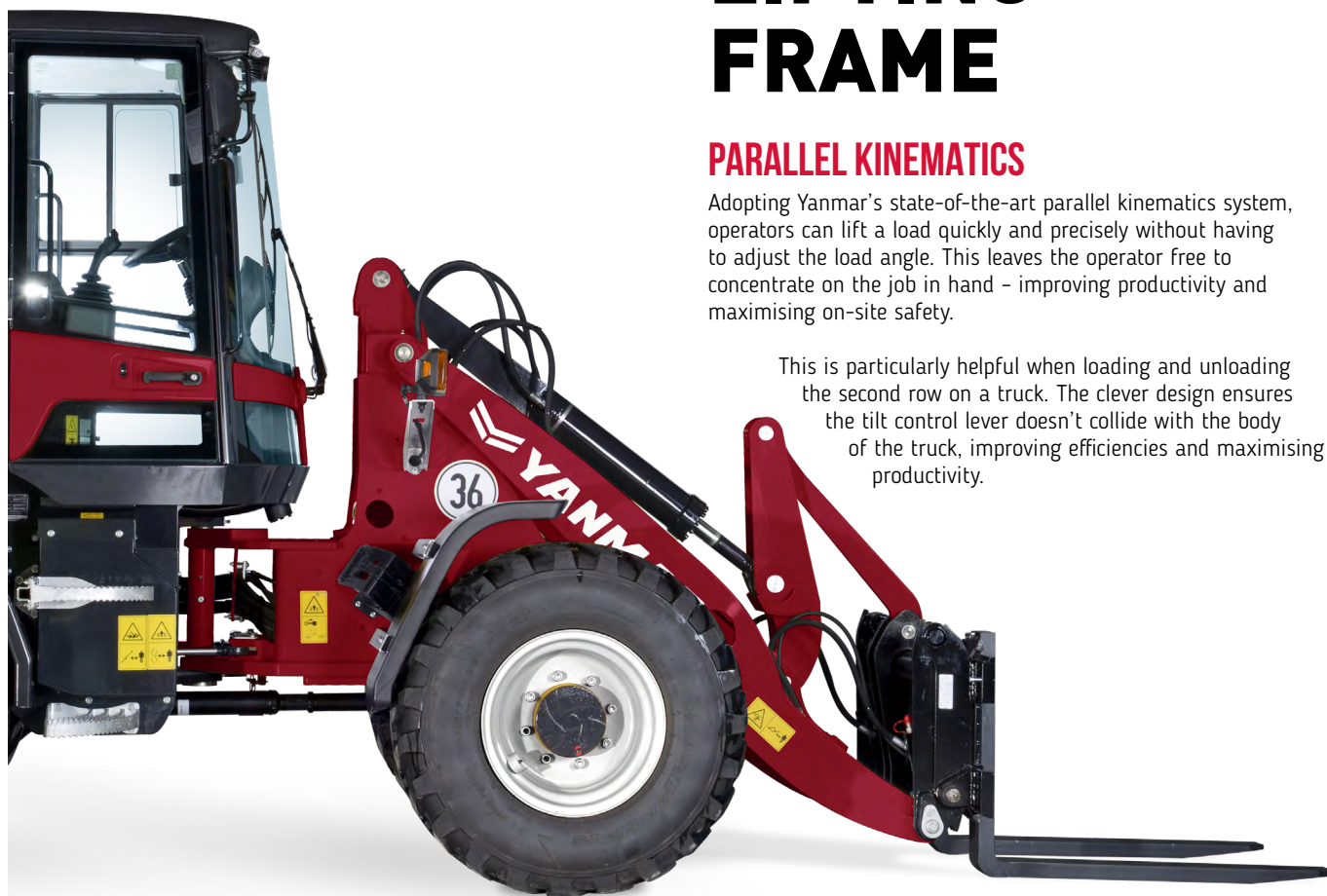

HYDRAULIC QUICK HITCH

Thanks to Yanmar's easy quick-hitch system, operators can switch tools directly from the cabin. Two-handed operation allows fast and smooth attachment changes.



POWERLINE



TAKE ADVANTAGE OF THE NEW ENGINE TECHNOLOGY

The V120 adopts a highly efficient diesel engine, which delivers impressive power and performance while meeting EU Stage V emissions regulations. Achieving a significant reduction in particulate emissions, the engine has a low environmental impact.

LOW EMISSIONS, HIGH FUEL ECONOMY

- + The EU Stage V engine delivers unmatched performance and achieves impressive fuel economy
- + Fitted with a Diesel Particulate Filter (DPF) as standard, operators benefit from lower servicing costs
- + Enhanced exhaust after-treatment, comprising improved combustion/injection systems and a Diesel Oxidation Catalyst (DOC) reduce emissions pollutants by up to 90%
- + The Selective Catalytic Reduction (SCR) module ensures that the correct amount and proportions of AdBlue solution are injected to break down NOx into water and non-toxic nitrogen.



HYDROSTATIC TRANSMISSION

High-pressure hydrostatic transmission ensures maximum productivity thanks to hydrostatic drive technology - offering smooth power delivery without unnecessary traction interruption.

WORKING HYDRAULICS

The working hydraulics (3rd section) operate completely independently from the transmission hydraulics. This enables effective operation of the hydraulic quick coupler and work attachments.

An additional control circuit (4th section) operates special attachments, which requires hydraulic oil flow (optional) and is available with High Flow function (optional).

The thermostatically controlled oil circuit ensures that the optimum oil temperature is reached quickly, while simultaneously preventing overheating.

A return filter, installed in the oil tank, enables simple replacement of filter elements.

AUTOMATIC DIFFERENTIAL LOCK

The V120 is equipped with permanent all-wheel drive and automatic self-locking differentials on both the front and rear axles (35% locking effort). This provides excellent traction when travelling and is perfect for bucket loading.

TRAVEL RIDE CONTROL

Yanmar's travel ride control function uses an accumulator to achieve a suspension effect in the boom cylinder. The system improves drivability on uneven ground, or when travelling at high speed, and further improves operator comfort.

TRACTIVE FORCE

Thanks to the addition of hydrostatic transmission, operators benefit from impressive power and smooth machine control. A high rim pull ensures effective pushing and digging, as well as good travel performance (even on steep inclines).

EASE OF USE

SMART CONTROL OPERATING SYSTEM

Each of Yanmar's class-leading wheel loaders feature Smart Control operating technology. The proprietary system delivers fast and intuitive machine control, while improving monitoring capabilities. Key features include:

- + A 3.5" screen displaying performance and engine data
- + Ergonomic controls with a smart phone inspired menu guide
- + Full control of the 3rd & 4th electric proportional hydraulic circuit
- + Custom settings to suit driver requirements

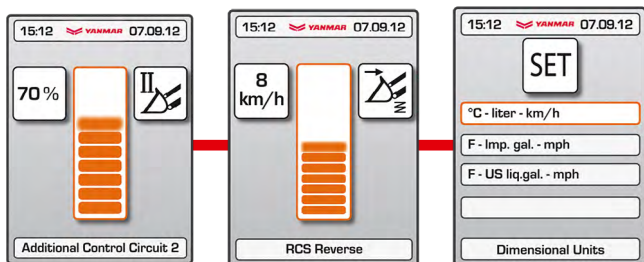

Electrical proportional adjustment of the hydraulic performance of the 3rd circuit

Activation of the motion control function at specific speed

Choice of units of measurement by country



LARGE KEYPAD

The V120 features a Diesel Particulate Filter (DPF) as standard, which helps to improve fuel consumption and saves on servicing costs.



ADJUSTABLE STEERING COLUMN

The adjustable steering column is part of the standard equipment of the machine. It improves the operator comfort and makes it easier to enter and exit the cabin from both sides.



COMFORT



Designed with driver comfort and productivity in mind, the cabine features noise and vibration damping and is ROPS/FOPS- approved.

IMPRESSIVE VISIBILITY

Thanks to large windows and ergonomic cab design, operators benefit from excellent visibility - both of the jobsite and loader attachments.

SECOND DOOR

- + Excellent ventilation
- + Access from either side
- + Easy to clean
- + Improved visibility, even at ground level



FULLY-ADJUSTABLE SEAT

Designed to priorities operator comfort, the V120 features a fully-adjustable seat with hydraulic suspension and weight.

FINGERTIP CONTROL

Fingertip control allows the operator to precisely regulate the oil flow (from zero to full), while electrical proportional activation of hydraulic functions is achieved through a thumbwheel on the joystick. These small details further improve operator comfort and maximise productivity.



PERFORMANCE



TRAVEL SPEED

Operating in a closed circuit, the hydrostatic travel drive delivers lots of power while keeping fuel consumption low. The V120 loader can achieve up to 20km/h on the road.

As an option, the V120 is also available in high speed version with a speed from 0 to 36km/h.



BRAKE INCHING PEDAL

By using the inch brake pedal, fine-tuning of the hydraulic performance is possible. The driver can modify the power between the drive and the working hydraulics. It allows to slow down the loader while keeping the engine rpm up. This feature improves the cycle time of digging and loading operations. This inch brake pedal prevents wheel spin and avoids excessive wear of the tires.



MANAGEABLE MAINTENANCE

The large engine hood provides easy access to all major service items, helping to improve maintenance speed and reducing Total Cost of Ownership. Daily tasks can be performed quickly and easily from ground level - maximum safety on site.



BATTERY MAIN SWITCH

Can be accessed quickly, safely and easily when standing next to the cab.



SEPARATE BATTERY POLES

Available as an option, this allows easy restarts thanks to free access under the engine hood.



CAB CABLING

Clever design allows the simple disconnection of electrical lines when dismantling the cab.



TAILORED FOR YOUR JOB



PROTECTION PACKAGE FOR HARSH ENVIRONMENTS

- + Special coating
- + Piston rods for lift, tilt, and steering cylinders with chrome/nickel coating (instead of the standard chrome coating)

LIFTING ARM

- + Burst valves for lift and tilt cylinders

HYDRAULICS

- + Fourth hydraulic control circuit
- + Biodegradable hydraulic oil
- + Pressure relief valve
- + Hydraulic shock absorbers

ROAD PERMISSION

The V120 may be driven on the road and can be used with an optional towing hitch as a tractor unit.

CABIN

- + FOPS II modification kit (protection against falling objects)
- + Heated external mirror
- + Supplementary diesel heating (independent of engine) with circulation system
- + Sliding window on right-hand side
- + Air conditioning
- + LED working lights rear and front
- + USB charger

MAINTENANCE

- + Central lubrication
- + Electric refueling pump

OPERATION

- + Reverse signal
- + Electronic immobiliser
- + Creeper gear

DIMENSIONS

GENERAL-PURPOSE BUCKET

Capacity in compliance with ISO 7546: 1.20 m³
 Max. density of material: 1.8 t/m³

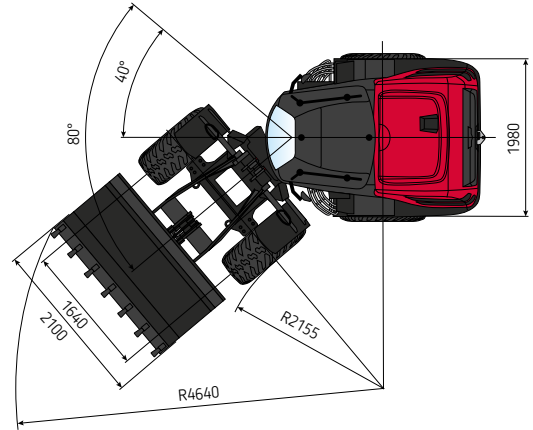
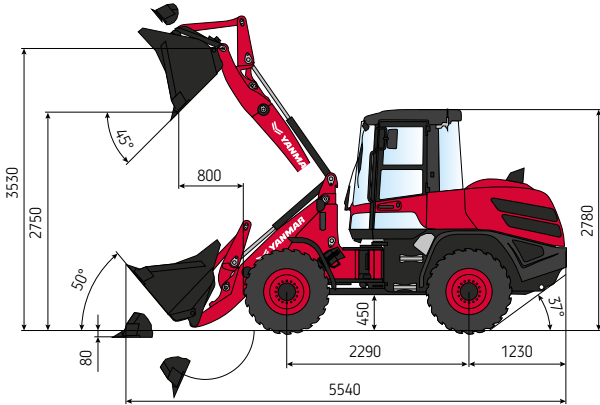

FORK LIFT ATTACHMENT

Operating load over total lift range: 2900 (3100*) kg
 Operating load in transport position: 3500* kg
*With rear axle weights

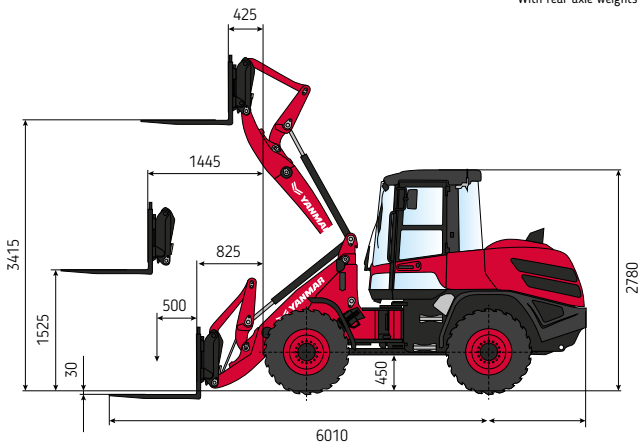

MULTI-PURPOSE BUCKET

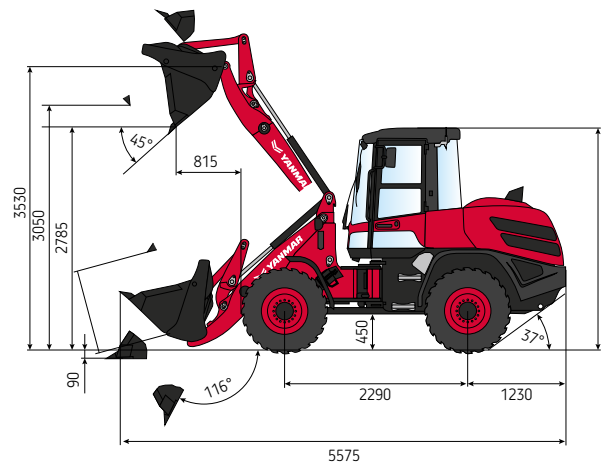

Overall length	5 480 mm
Wheelbase	2 290 mm
Overall height	2 780 mm
Ground clearance (below cardan shaft)	460 mm
Overall width (outside of tires/ bucket)	2 100 mm / 1 980 mm
Dumping height (w/o teeth)	2 680 mm
Dumping reach (w/o teeth)	790 mm
Max. hinge pin height	3 520 mm
Max. lifting height	3 365 mm
Digging depth	70 mm
Tilt back angle (at traveling position) Deg.	50°
Dumping angle Deg.	45°
Articulation angle Deg.	40°
Turning radius (track circle/ bucket circle)	2 155 mm / 4 680 mm

SPECIFICATIONS

STANDARD EQUIPMENT

[ENGINE]

Manufacturer, model	Deutz TCD 3.6 L4 EU
Type	4-cylinders turbo diesel EU Stage V engine with charge cooler, US EPA, Tier 4
Combustion	4-cylinder cycle, common rail injection
Number of cylinders	4 in line
Displacement	3 600 m ³
Net Power	2 000 rpm 74,4 kW (101 hp)
Max. torque	410 Nm at 1 600 rpm (69 kW)
Cooling system	Water
Guard for fan wheel	

[ELECTRICAL SYSTEM]

Nominal voltage	12 V
Battery	12 V / 100 Ah
Generator	14 V / 95 A
Starter	12 V / 2,6 kW
Cold-starting aid	Glow plugs 12V
Battery main switch	

[HYDRAULIC SYSTEM]

Travel hydraulics: Closed circuit, independent from working hydraulics.

Pump capacity max.	166 L/min
Travel pressure max.	440 bar

Working hydraulics: Gear pump on through drive of variable displacement pump.

Pump capacity max.	81 L/min
Working pressure max.	250 bar

The thermostatically controlled oil circuit ensures that the oil temperature is promptly reached and avoids overheating. Return filter installed in oil tank allows for eco-friendly replacement of filter elements.

[CABIN]

Flexibly mounted full-view steel cab, ROPS (as per ISO 3471) and FOPS (as per EN ISO 3449) certified, with roof grating only (option).

The driver's cab is equipped with:

2 doors, 180 ° hinged and foldable external mirrors.

Electric windshield wipers with interval switching.

Washing system, front and rear.

Panorama, bronze-tinted safety glass with sunroof.

2 front working LED floodlights.

Cab heating via engine coolant - heat exchanger with 3-step heating fan (switch from fresh air to air recirculation), 2 vents each for the front wind screen, footwell and rear windows.

Window defroster, front and rear.

Sound-dampened lining.

[AXLES]

Front: Rigid planetary final drive axle, centre-mounted disc brake. Limit slip-type differential 45%

Rear: Oscillating planetary drive axle, oscillating angle

8°

SPECIFICATIONS

[UNDERCARRIAGE AND TIRES]

Front axles: Rigid planetary final drive axle, center-mounted disc brake. Limit slip-type differential 45%

Rear axles: Oscillating planetary drive axle, oscillating angle. Angle of oscillation $\pm 8^\circ$

Tires: Standard 405/70 R 20

[BRAKES]

Hydraulically actuated center-mounted disk brake, acting on all 4 wheels via 4-wheel drive.

Additional brake: hydrostatic through closed-circuit travel drive.

Further additional brake (only high-speed version): Hydraulic pump accumulator brake, acting on oil-immersed multi-disc brakes of rear axle.

Auxiliary brake: Hydrostatic travel drive in closed circuit acting as non-wearing auxiliary brake.

Parking brake: Hydraulic spring-loaded brake, electrically actuated.

[PERFORMANCE]

Hydrostatic drive, closed circuit, independent from loader hydraulics. Automatic optimization and adjustment of propulsive force and speed. The travel drive in closed circuit additionally acts as a non-wearing service brake. Continuous speed regulation forward and in reverse. Four-wheel drive via propeller shaft connection. Inch-brake-pedal for sensitive driving and stopping at high engine speeds.

Travel speed range	0-20 km/h
Static tipping load (straight / full turn)	5 000 kg / 4 400 kg
Max. breakout force (acc. to ISO 6015)	59 kN
Max. digging force (acc. to ISO 6015)	55 kN
Gradability	1,20 m ³
Noise level (LpA / LwA)	102 dB

[SAFETY]

Fully hydraulically controlled articulated steering.

Max. steering angle 40°

Driver's seat MSG85 with hydraulic suspension, weight adjustable, longitudinal and height adjustment and lap belt in compliance with ISO 7096 & ISO 6683.

Rear-view mirrors foldable.

Self-lock differential 45% in front and rear axle.

Inch brake pedal

[VIBRATION VALUES (IN COMPLIANCE WITH DIRECTIVE 2006/42/EC & EN474)]

Effective values of acceleration below for entire body	0.5 m/s ²
Effective values of acceleration below for hand-arm	2.5 m/s ²

[CAPACITIES]

Fuel tank	110 l
Engine oil	8 l
Hydraulic tank	93 l
AdBlue Tank	10 l

[MISCELLANEOUS]

Multifunction display / Smart Control : the driver can adjust the machine exactly to the environment, operation, and individual specific requirements.

[MAINTENANCE FREQUENCY]

Change engine sump oil	500 h
Change engine oil filter	500 h
Change engine fuel filter	1 000 h
Change hydraulic oil	1 000 h
Change cooling fluid	According to demand (at least all 2 years)

SPECIFICATIONS

[OPTIONAL EQUIPMENT]

ENGINE

Diesel EU Stage V engine with Diesel Particulate Filter (DPF) | High-speed version 36 km/h | Manual throttle for engine rpm with shutdown hydrostatic transmission.

HYDRAULIC SYSTEM

4th control circuit and installation on lift frame, include couplings and continuous operation e. g. for attachments with 2 hydraulic functions | Hydraulic outlet for front hand-held hammer, with flow divider | Open return, on lift frame | Bypass filter Kleenoil.

CABINE

FOPS skylight guard | Yellow beacon | Right-hand door with sliding window | Radio installation kit | 1 or 2 additional working floodlight back side - cab-mounted | Air-conditioning | Left door sliding window | Right-hand side sliding window | Seat MSG 95 (premium): air damping, extra-high backrest and tilt-adjustable armrests, longitudinal-horizontal suspension, seat and backrest heating, pneumatic lumbar support.

TIRES

400/70 R20 Michelin Bibload | 400/75 R 20 XMCL Michelin | 500/45 R20 Alliance 20 | 10.00-20 Nexen Solid | Other non-standard tires available on request.

SAFETY

Bucket & loader arm cylinder safety block valve | Descent regulation valve.

COUPLERS

Ball head coupler | Rockinger trailer coupling.

MISCELLANEOUS

Central lubrication unit | Special paint | Bio oil | Anti-theft device (immobilizer) | Electrical tank refilling pump | Rear axle weights, approx. 260 kg | Pilot-controlled hose-rupture valves for lift and tilt cylinders | Quick couplers (flat face) for 3rd control circuit on lift frame | Back-up alarm for reverse travel | Travel ride control system | Acceptance as agricultural or forestry tractor | Further optional equipment available on request | Standard lifting frame P-Kinematic | Extended lifting frame (+ 500 mm) P-Kinematic.

[OPTIONAL EQUIPMENT]

	Contents	Density	Width	Dump height
General-purpose bucket, quick-attach system, teeth	1,20 m ³	1,8 t/m ³	2 100 mm	2 750 mm
General-purpose bucket, quick-attach system, bolt-on cutting edge	1,20 m ³	1,8 t/m ³	2 100 mm	2 710 mm
Earth bucket, quick-attach system, teeth	1,35 m ³	1,6 t/m ³	2 100 mm	2 700 mm
Earth bucket, quick-attach system, bolt-on cutting edge	1,35 m ³	1,6 t/m ³	2 100 mm	2 660 mm
Light-material bucket, bolt-on cutting edge	1,55 m ³	1,2 t/m ³	2 100 mm	2 610 mm
Light-material bucket, bolt-on cutting edge	1,80 m ³	0,8 t/m ³	2 200 mm	2 550 mm
Multi-purpose bucket, quick-attach system	1,05 m ³	1,6 t/m ³	2 100 mm	2 785 mm
Side-dump bucket, quick-attach system, without teeth	0,85 m ³	1,8 t/m ³	2 100 mm	2 665 mm
High-tip bucket, quick-attach system, without teeth	1,20 m ³	1,2 t/m ³	2 100 mm	3 970 mm
High-tip bucket, quick-attach system, without teeth	1,80 m ³	0,6 t/m ³	2 200 mm	4 030 mm
Quarry bucket, quick-attach system	0,95 m ³	2,1 t/m ³	2 100 mm	2 780 mm
Compost bucket	1,20 m ³	1,2 t/m ³	2 100 mm	2 750 mm



YANMAR



Yanmar Compact Equipment EMEA

GB_V120_0122



www.yanmar.com